

VIEW B

ITEM NO.	PART NUMBER	DESCRIPTION	QTY
1	PLOW-52-PCF	52" FRAME WELDMENT	1
2	PLOW-13	ATTACH BOX	1
3	PLOW-PL-02	EXTENSION SPRING	4
4	PLOW-07	WEAR SHOE ASSY	2
5	PLOW-28W	WASHER FOR KING BOLT	6
6	PLOW-38-BP	BULL DOZER PIN	2
7	PLOW-38C	HAIRPIN COTTER PIN	2
8	PLOW-52-MB	MOLDBOARD SKIN	1
9	PLOW-04-52	CUTTING EDGE	1
10	PLOW-KING	3/4-10 X 3-1/2" LG HEX BOLT	1
11	RBK-34LN	3/4-10 LOCK NUT	1
12	PLOW-18	3/8-16 X 3" SHANK EYE BOLT	4
13	PLOW-38N	3/8"-16 HEX NUT	11
14	PLOW-28	1/2-13 X 1-1/2" LG HEX BOLT	2
15	PLOW-3B	1/2-13 X 3-1/2" LG HEX BOLT	2
16	PLOW-1/2 FW	1/2 FLAT WASHER	12
17	PLOW 13LN	1/2-13 LOCKNUT	4
18	CDC BSP-1936	BUSHING	2
19	PLOW-12	9/16 WASHER	2
20	PLOW-38B	3/8-16 x 1" LG CARRIAGE BOLT	7
21	PLOW-38-LN	3/8 SPLIT LOCK WASHER	7

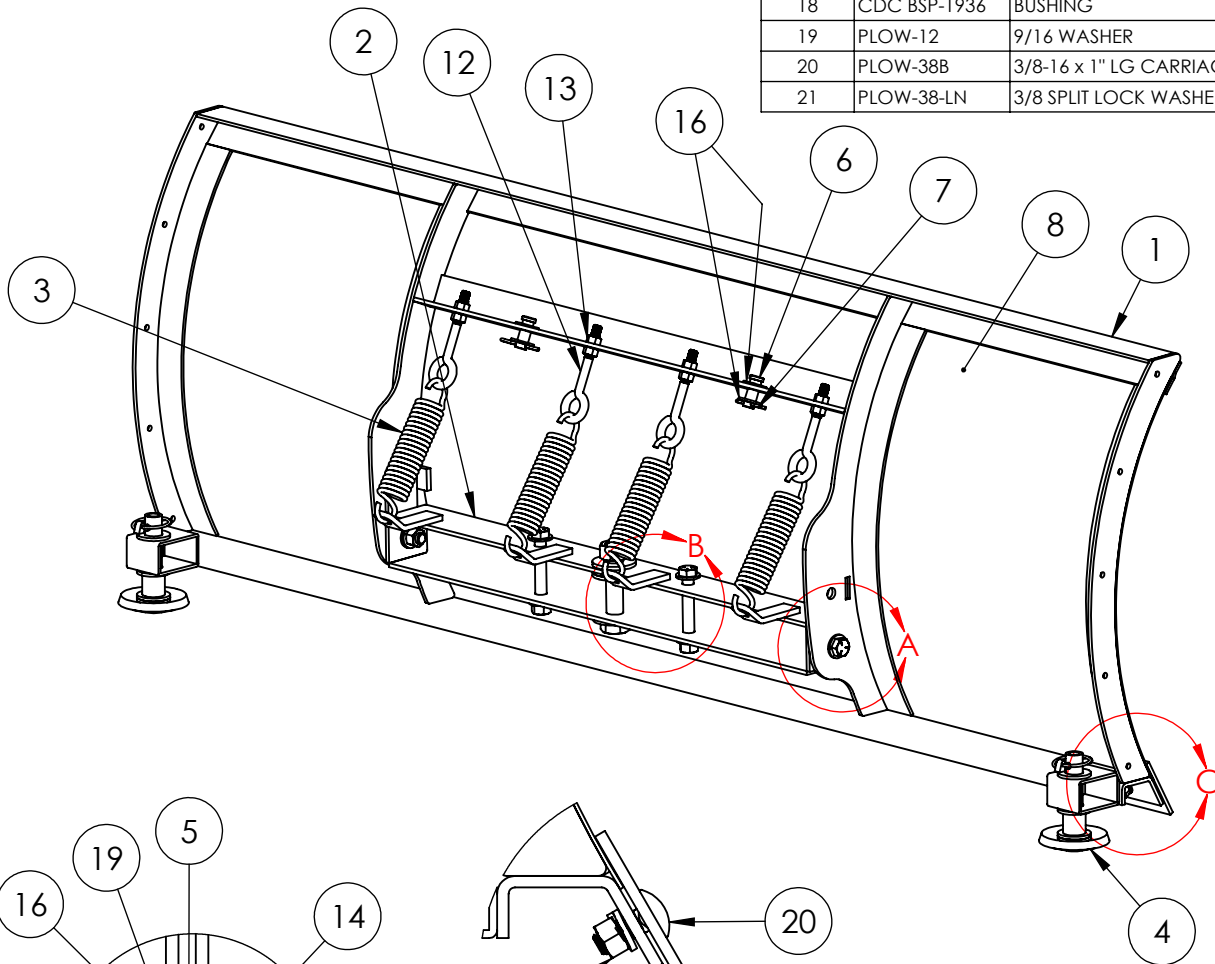

52" Plow with Standard cutting edge

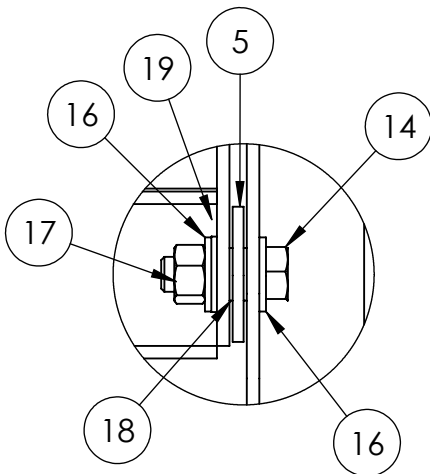

VIEW A

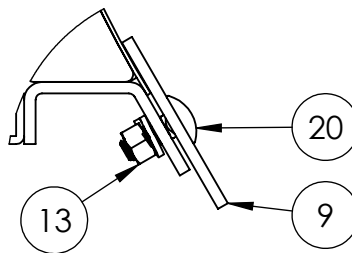

VIEW C

DIMENSIONS ARE IN INCHES TOLERANCES: FRACTIONAL: $\pm 1/16$ ANGULAR: $\pm 1^\circ$ X.X $\pm .1$ X.XX $\pm .06$ X.XXX $\pm .010$	NAME	DATE		
	DRAWN	CML		10/4/2018
	MATERIAL	COMMENTS:		DESCRIPTION <h2>52" PLOW</h2>
	NOTED	<small> NOTICE: THIS DOCUMENT IS TRANSMITTED SOLELY FOR THE PURPOSE OF AIDING THE TRANSACTION OF BUSINESS BETWEEN BLACKLINE TM AND THE RECIPIENT AND MUST BE RETURNED ON REQUEST. ALL DRAWINGS, INFORMATION AND DATA INCLUDING ALL DESIGNS AND CONCEPTS CONTAINED HEREON ARE THE PROPERTY OF BLACKLINE TM AND MAY NOT BE REPRODUCED OR COPIED IN WHOLE OR IN PART NOR APPROPRIATED TO USE(S) IN ANY WAY DETRIMENTAL TO THE INTERESTS OF BLACKLINE TM INCLUDING DISCLOSURE TO OUTSIDE PARTIES, DIRECTLY OR INDIRECTLY. NOR CAN IT BE USED FOR THE MANUFACTURE OF ANY EQUIPMENT DESCRIBED WITHOUT THE SPECIFIC WRITTEN CONSENT OF BLACKLINE TM. </small>		
FINISH	SIZE	DWG. NO.	REV.	
DO NOT SCALE DRAWING	A	PLOW-52	A	
	SCALE: 1:8	WEIGHT: 85.75	SHEET 1 OF 2	